

## ORDER REFERENCE

PROJECT: XX

GENERAL CONTRACTOR: -

EQUIPMENT INSTALLED BY: XX

## SPECIFICATIONS

MODEL: DW-500

LANDINGS: 2

CODE(S): 5

CAPACITY: 500#

SPEED: AT 33 F.P.M.±4

SUSPENSION MEANS: 1 WIRE ROPE 5,700 T.S. IMP.PLOW  
STEEL 1/4" x 8 x 19 WSC

CAR CONSTRUCTION: X

NOTE: ALL MANUFACTURER SUPPLIED CAR AND EQUIPMENT OPTIONS ARE NOTED ON THE CONFIRMING ORDER SHEET.

**DISCLAIMER:** ONCE DRAWINGS HAVE BEEN APPROVED, SIGNED AND WITHIN 5 DAYS OF PRODUCTION, THE CUSTOMER WILL BEAR ALL RESPONSIBILITY AND LIABILITY OF FINISHED UNIT.

PLEASE REFER ANY QUESTION TO YOUR SALES REPRESENTATIVE

APPROVED

UNAPPROVED

\_\_\_\_\_  
SIGNATURE

\_\_\_\_\_  
DATE

DWG VIEW COVER SHEET		PART NUMBER 80205321			REV.DATE -	
DRAWING TITLE DW- 500# OVERHEAD		DRAWING NO. -			-	
PAGE: 1/4	DRAWN BY: D.LUCASSEN	DWG. DATE 01/08/07	JOB OR APP.# -	DEALER P.O.# -	DWG. SCALE 1:24	REV.LEVEL(1-3) -



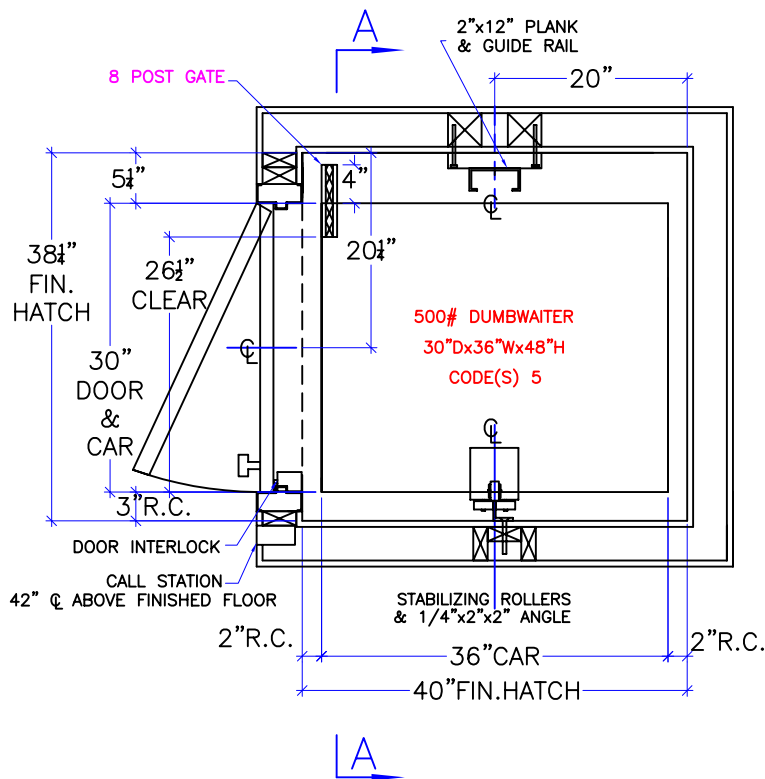

NOTE:  
2" RUNNING CLEARANCE  
MUST BE REDUCED TO  
1/2" MIN./1 1/2" MAX.  
AT THE LANDING LEVELS.

NOTE:  
ALL HOISTWAY CONSTRUCTION MUST COMPLY WITH NATIONAL, STATE,  
AND LOCAL  
CODES. HOISTWAY MUST BE PLUMB AND STRAIGHT FROM TOP TO  
BOTTOM WITH NO PROJECTIONS INTO THE HOISTWAY.

NOTE:  
G.C. TO BUILD OUT HOISTWAY  
AS NEEDED TO MAINTAIN 3"  
REQUIRED FOR STABILIZER.

**NOTICE TO ELECTRICAL CONTRACTOR:**

- ALL ELECTRICAL WIRING MUST BE DONE BY A JOURNEYMAN MECHANIC AND MUST MEET ALL NATIONAL, STATE, AND LOCAL CODES.
- BRING (3) #10 W/GND FROM RESIDENCE INCOMING POWER PANEL 30AMP BREAKER(240V, NEUTRAL, GROUND)TO THE MACHINE ROOM.
- BRING (2) #12 W/GND FROM RESIDENCE INCOMING POWER PANEL 20AMP GFI BREAKER(120V, NEUTRAL, GROUND)TO THE MACHINE ROOM.
- REQUIRED LOW VOTAGE WIRING IS SUPPLIED BY MANUFACTURER. ALL EXTENSIONS ADDITIONS, ETC. SHALL BE DONE WITH THE SAME SIZE AND TYPE OF WIRE AS ORIGINALLY SUPPLIED BY THE MANUFACTURER.
- ALL MEANS FOR ACCESS TO EQUIPMENT SHALL BE PROVIDED WITH A LOCK. ALL SHAFT DOORS MUST BE INTERLOCKED.

DWG VIEW

HOISTWAY LAYOUT

PART NUMBER

80205321

REV.DATE

-

-

-



DRAWING TITLE

DW- 500# OVERHEAD

DRAWING NO.

-

PAGE:  
2/4

DRAWN BY:  
D.LUCASSEN

DWG. DATE  
01/08/07

JOB OR APP.#  
-

DEALER P.O.#  
-

DWG. SCALE  
1:24

REV.LEVEL(1-3)  
-

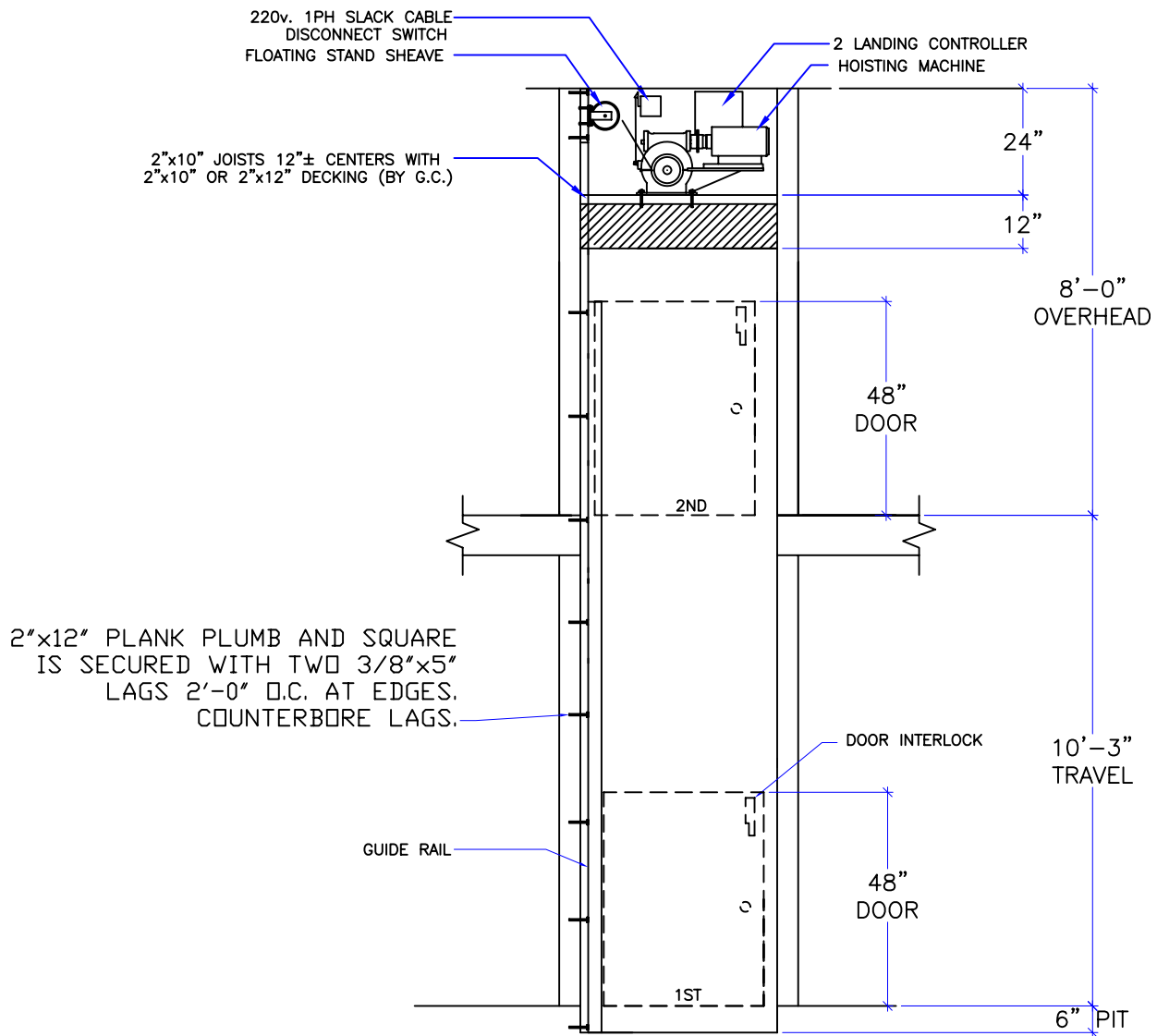

DWG VIEW		SECTION A-A		PART NUMBER		REV. DATE	
				80205321		-	
INCLINATOR COMPANY OF AMERICA HARRISBURG, PA		DRAWING TITLE		DRAWING NO.		-	
		DW- 500# OVERHEAD		-		-	
PAGE:	DRAWN BY:	DWG. DATE	JOB OR APP.#	DEALER P.O.#	DWG. SCALE	REV. LEVEL(1-3)	
3/4	D.LUCASSEN	01/08/07	-	-	1:24	-	

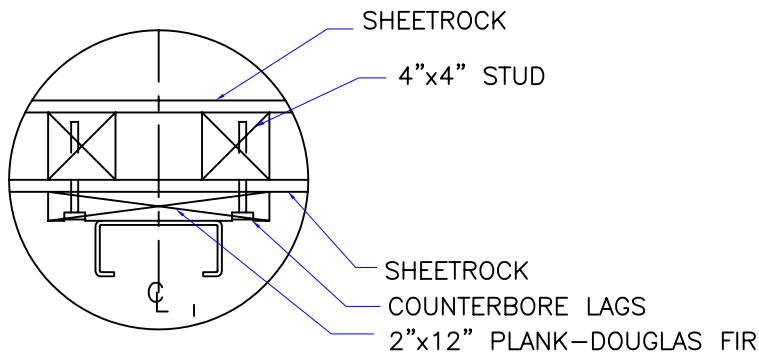

NOTE:  
 WHEN STUD AND SHEETROCK CONSTRUCTION IS USED ON THE GUIDE RAIL SUPPORT WALL 4"x4" STUDDING IS NEEDED BEHIND THE 2"x12" PLANK.

RAIL DETAIL

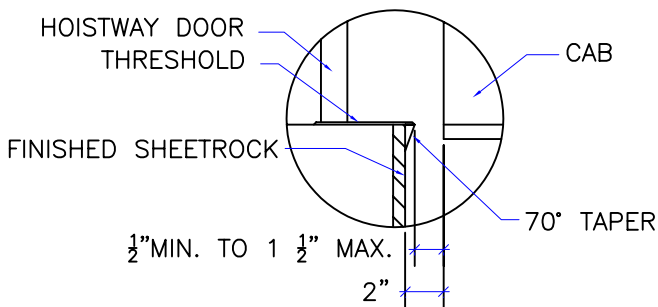

DOOR SILLS TO BE INSTALLED BY G.C. AFTER LIFT SUPPLIER HAS INSTALLED A RUNNING PLATFORM. SILL TO BE BROUGHT OUT TO NOT LESS THAN 1/2" AND NOT MORE THAN 1 1/2" TO THE RUNNING PLATFORM.

SILL DETAIL

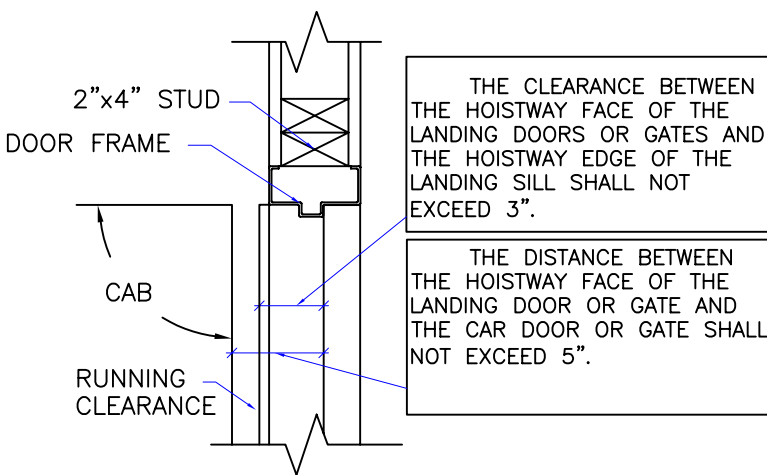

DOOR FRAME DETAIL

1. REACTIONS ON ALL SHEAVES AND MOUNTINGS  
 STATIC = 1,100 LBS.  
 IMPACT = 2,200 LBS.
2. RAIL FASTENING TO 2" x 12" PLANK  
 #14 x 1 3/4" TYPE A S.M.S. RAIL IS PRE-DRILLED AT FACTORY.
3. BOLT FASTENING OF CAR TO TROLLEY  
 1/2" - 13 x 4" SOCKET HD CAP SCREWS.

TECHNICAL DATA

DWG VIEW  
 DETAILS, DATA, CODES

PART NUMBER  
 80205321

REV.DATE

DRAWING TITLE  
 DW- 500# OVERHEAD

DRAWING NO.

**INCLINATOR**  
 COMPANY OF AMERICA  
 HARRISBURG, PA

PAGE: 4/4	DRAWN BY: D.LUCASSEN	DWG. DATE 01/08/07	JOB OR APP.# -	DEALER P.O.# -	DWG. SCALE 1:24	REV.LEVEL(1-3) -
--------------	-------------------------	-----------------------	-------------------	-------------------	--------------------	---------------------